

18Gbps USB-C over HDBaseT 3.0 Extender (70m) with USB 2.0



User Manual

VER 1.0

Thank you for purchasing this product

For optimum performance and safety, please read these instructions carefully before connecting, operating or adjusting this product. Please keep this manual for future reference.

Surge protection device recommended

This product contains sensitive electrical components that may be damaged by electrical spikes, surges, electric shock, lighting strikes, etc. Use of surge protection systems is highly recommended in order to protect and extend the life of your equipment.

Caution

The product requires the use of UTP connectors. Please connect in direct interconnection method and do not cross connect.

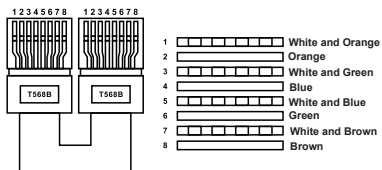

Direct Interconnection Method

Table of Contents

1. Introduction.....	1
2. Features.....	1
3. Package Contents.....	2
4. Specifications.....	2
5. Operation Controls and Functions.....	4
5.1 Transmitter Panel.....	4
5.2 Receiver Panel.....	5
6. API Commands.....	6
7. Application Example.....	10

1. Introduction

This 18Gbps HDBaseT 3.0 extender can extend USB-C video and USB 2.0 signals up to 230ft/70m for 4K30Hz (4:4:4 8bit) and 130ft/40m for 4K60Hz (4:4:4 8bit) via a single CAT6A/7 cable. The transmitter box (TX) features with 1x USB-C input, 1x dedicated USB-C charging port and 2x local USB devices. USB-C input supports DP Alt-mode standards (v1.2a) and USB 2.0 data. The receiver box (RX) features with 1x HDMI output and 4x USB devices. TX/RX both support RS-232 signal pass-through and bi-directional 24V PoC function. This extender offers the most convenient solution for video extension via a single CAT cable, and it is a perfect solution for commercial A/V applications.

2. Features

- ☆ HDBaseT 3.0 extender with USB-C input
- ☆ 18Gbps video bandwidth, and video resolution up to 4K@60Hz (4:4:4 8bit) as specified in HDMI 2.0b
- ☆ Extend uncompressed 4K60Hz (4:4:4 8bit) signal up to 130ft/40m and 4K30Hz (4:4:4 8bit) signal up to 230ft/70m with CAT6A/7 cable
- ☆ HDR, HDR10+, Dolby Vision LLM and HLG pass-through
- ☆ HDCP 2.3 compliant, to create a secure connection between the source and display
- ☆ The transmitter features 1x USB-C input, 1x dedicated USB-C charging port and 2x local USB devices
- ☆ USB-C input supports DP-ALT mode standards (v1.2a) for A/V, USB 2.0 data and power charging up to 100 watts
- ☆ The receiver features 1x HDMI output and 4x USB 2.0 devices
- ☆ USB 2.0 high speed over HDBaseT 3.0
- ☆ Each USB-A port provides power up to 5V/1A
- ☆ RS-232 signal pass-through
- ☆ Audio passthrough: LPCM 2.0/5.1/7.1CH, Dolby True HD, Dolby Atmos, DTS-HD Master Audio and DTS:X
- ☆ Bidirectional 24V PoC (power over cable), when TX or RX gets power, the other end does not need an external power supply
- ☆ Compact design for easy and flexible installation

3. Package Contents

- ① 1× 18Gbps USB-C over HDBaseT 3.0 Extender (Transmitter)
- ② 1× 18Gbps USB-C over HDBaseT 3.0 Extender (Receiver)
- ③ 2× 3pin-3.5mm Phoenix Connector (male)
- ④ 1× 24V/2.7A Desktop Power Supply
- ⑤ 1× User Manual

4. Specifications

Technical	
HDMI Compliance	HDMI 2.0b
HDCP Compliance	HDCP 2.3
USB Compliance	USB 2.0
Video Bandwidth	18Gbps
Video Resolution	Up to 4K@60Hz (4:4:4 8bit)
Color Space	RGB, YCbCr 4:4:4, YCbCr 4:2:2, YCbCr 4:2:0
Color Depth	8/10/12bit
HDR	HDR, HDR10, HDR10+, Dolby Vision, HLG
Audio Formats	USB-C/HDMI passthrough: LPCM 2.0/5.1/7.1CH, Dolby True HD, Dolby Atmos, DTS-HD Master Audio and DTS:X
Transmission Distance	<ul style="list-style-type: none">▪ Extend 4K60Hz (4:4:4 8bit) signal up to 130ft/40m and 4K30Hz (4:4:4 8bit) signal up to 230ft/70m with CAT6A/7 cable▪ USB 2.0 pass through up to 230ft/70m, connecting to 4 USB devices to the receiver
ESD Protection	IEC 61000-4-2: ±8kV (Air-gap discharge) & ±4kV (Contact discharge)

Connection	
Transmitter	<p>Front Panel: 1x CHARGE [USB Type C, 24-pin female] 1x USB-C IN [USB Type C, 24-pin female] 2x USB 2.0 DEVICES [USB Type A, 4-pin female]</p> <p>Rear Panel: 1x SERVICE [USB-C with USB 2.0 only, 12-pin female, firmware upgrade port] 1x RS-232 [3-pin phoenix with 3.5mm pitch] 1x HDBaseT OUT [RJ45 connector, 24V PoC] 1x Power LED [Red LED, Power indicator] 1x DC 24V [24V/2.7A, 19mm locking connector]</p> <p>Side Panel: 1x PoC ON/OFF [1-pin DIP switch, 24V PoC ON/OFF selection]</p>
Receiver	<p>Front Panel: 1x HDMI OUT [HDMI Type A, 19-pin female] 1x USB 2.0 DEVICES [USB Type C, 12-pin female] 3x USB 2.0 DEVICES [USB Type A, 4-pin female]</p> <p>Rear Panel: 1x SERVICE [USB-C with USB 2.0 only, 12-pin female, firmware upgrade port] 1x RS-232 [3-pin phoenix with 3.5mm pitch] 1x HDBaseT IN [RJ45 connector, 24V PoC] 1x Power LED [Red LED, Power indicator] 1x DC 24V [24V/2.7A, 19mm locking connector]</p> <p>Side Panel: 1x PoC ON/OFF [1-pin DIP switch, 24V PoC ON/OFF selection]</p>
Mechanical	
Housing	Metal Enclosure
Color	Black
Dimensions	Transmitter/Receiver: 120mm [W] x 113mm [D] x 25.5mm [H]
Weight	Transmitter: 353g, Receiver: 352g
Power Supply	Input: AC 100 - 240V 50/60Hz Output: DC 24V/2.7A (US/EU standard, CE/FCC/UL certified)
Power Consumption	TX/RX with full USB devices: 51.36W TX/RX without USB devices: 10.08W
Operating Temperature	32°F - 104°F / 0°C - 40°C
Storage Temperature	-4°F - 140°F / -20°C - 60°C
Operating Humidity	20% - 80% relative humidity, non-condensing
Storage Humidity	10% - 90% relative humidity, non-condensing

5. Operation Controls and Functions

5.1 Transmitter Panel

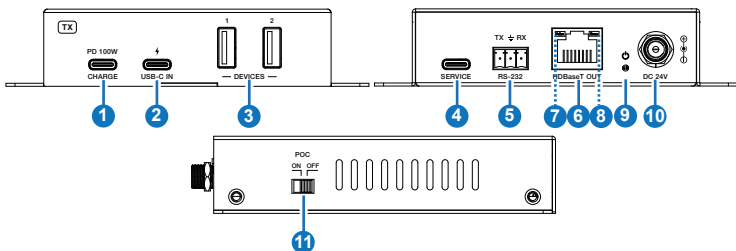

No.	Name	Function Description
1	CHARGE port	USB Type C power input port, supporting up to 100W power input. Connect this port to an external USB-C charger, then the USB-C IN port can power the connected device.
2	USB-C IN port	USB Type C port with following three functions: (1) USB audio/video signal input port, connected to source device. (2) USB 2.0 signal transmission port. (3) USB-C charging port. Only when the CHARGE port is connected to the power supply, the USB-C IN port can provides 100W charging power for external USB-C devices.
3	DEVICES 1-2 ports	Two USB 2.0 ports, connected to USB Flash Drive, keyboard, USB camera or other USB devices, with a maximum power supply of 5V/1A.
4	SERVICE port	Firmware update and API command control port.
5	RS-232 port	RS-232 serial port, used for RS-232 signal pass-through.
6	HDBaseT OUT port	HDBaseT output port, connected to the HDBaseT IN port of the receiver with a CAT6A cable. It is used for various signals pass-through.

No.	Name	Function Description
7	Signal LED (Yellow)	<ul style="list-style-type: none"> Light on: There is video signal transmission with HDCP encryption. Light flashing: There is video signal transmission without HDCP encryption. Light off: There is no video signal transmission.
8	Link LED (Green)	<ul style="list-style-type: none"> Light on: Transmitter and receiver are linked. Light off: Transmitter and receiver are not linked.
9	Power LED (Red)	<ul style="list-style-type: none"> Light on: The transmitter is powered on. Light off: The transmitter is powered off.
10	DC 24V	DC 24V/2.7A power supply input port. <i>Note that the extender supports PoC function, it means that either transmitter or receiver is powered on by 24V/2.7A power adapter, the other one doesn't need power supply.</i>
11	PoC switch	Use the switch to turn on/off the PoC function.

5.2 Receiver Panel

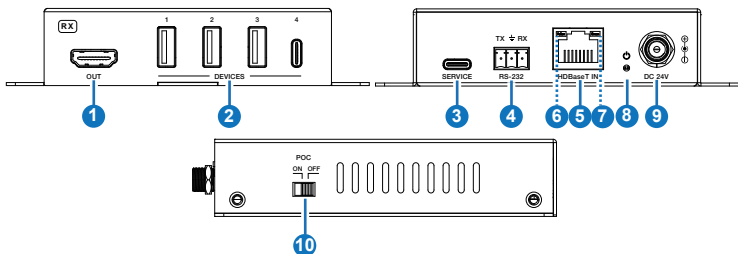

No.	Name	Function Description
1	OUT port	HDMI signal output port, connected to HDMI display device, such as TV or monitor.
2	DEVICES 1-4 ports	Four USB 2.0 ports (three USB-A ports and one USB-C port), connected to USB Flash Drive, keyboard, USB camera or other USB devices, with a maximum power supply of 5V/1A.
3	SERVICE port	Firmware update port.

No.	Name	Function Description
4	RS-232 port	RS-232 serial port, used for RS-232 signal pass-through.
5	HDBaseT IN port	HDBaseT input port, connected to the HDBaseT OUT port of the transmitter with a CAT6A cable. It is used for various signals pass-through.
6	Signal LED (Yellow)	<ul style="list-style-type: none"> ▪ Light on: There is video signal transmission with HDCP encryption. ▪ Light flashing: There is video signal transmission without HDCP encryption. ▪ Light off: There is no video signal transmission.
7	Link LED (Green)	<ul style="list-style-type: none"> ▪ Light on: Transmitter and receiver are linked. ▪ Light off: Transmitter and receiver are not linked.
8	Power LED (Red)	<ul style="list-style-type: none"> ▪ Light on: The receiver is powered on. ▪ Light off: The receiver is powered off.
9	DC 24V	DC 24V/2.7A power supply input port. <i>Note that the extender supports PoC function, it means that either transmitter or receiver is powered on by 24V/2.7A power adapter, the other one doesn't need power supply.</i>
10	PoC switch	Use the switch to turn on/off the PoC function.

6. API Commands

The extender also supports API commands control. Connect the SERVICE port of the transmitter to a PC or control system with a USB-C cable. Then, open a serial command tool on PC to send ASCII commands to control the extender. The ASCII commands list about the extender is shown as below.

ASCII Commands				
SERVICE (USB-C port with virtual RS-232) communication protocol (Connect to laptop)				
Baud rate: 115200 (Fixed) Data bit: 8 Stop bit: 1 Parity bit: none				
The end mark of command is "<CR><LF>"				
Command	Function	Example	Feedback	Default
?	Get the list of all commands	?	List all commands	
help	Get the list of all commands	help	List all commands	
get fw version	Get the firmware version	get fw version	FW V1.00.00	

Command	Function	Example	Feedback	Default
set reboot	Reboot the device	set reboot	Reboot... System Initializing... Initialization Finished! FW V1.00.00	
set reset	Reset to factory defaults	set reset	Sure to RESET to default settings? Type "Yes" after next prompt to confirm...	
get status	Get system status	get status	Please refer to the note for "get status".	
set tx source x	Set TX input source(x=0~3) x=0: OFF x=1: USB-C input x=2: AVMUTE x=3: Internal pattern	set tx source 1 set tx source 0	Set TX source to USB-C Set TX source to OFF	1
get tx source	Get TX input source	get tx source	USB-C	
set tx pattern x y	Set TX internal pattern generator resolution (x=1~7) pattern (y=1~12) x=01: 1080P60Hz x=02: 4K60Hz x=03: 4K30Hz x=04: 4K25Hz x=05: 4K24Hz x=06: 720P60Hz x=07: 480P60Hz y=01: Black y=02: Checkboard y=03: Strip y=04: Red y=05: Green y=06: Blue y=07: White y=08: Ramp y=09: Red ramp y=10: Green ramp y=11: Blue ramp y=12: PRBS	set tx pattern 1 2	Set TX pattern 1080P60Hz checkboard	
get tx pattern	Get TX internal pattern generator output resolution and pattern	get tx pattern	TX pattern 1080P60Hz checkboard	
set tx input hdcp y	Set TX input HDCP to (y=0~2) y=0: HDCP OFF y=1: HDCP 1.4 y=2: HDCP 2.2	set tx input hdcp 2 set tx input hdcp 0	Set TX input HDCP 2.2 Set TX input HDCP OFF	HDCP 2.2

Command	Function	Example	Feedback	Default
get tx input hdcp	Get TX input HDCP status	get tx input hdcp	TX input HDCP 2.2	
set tx output hdcp y	Set TX output HDCP mode to (y=0~4) y=0: Reserved y=1: Follow sink (default) y=2: Follow source y=3: Force HDCP 1.4 y=4: Force HDCP 2.2	set tx output hdcp 1	Set TX output HDCP to follow sink	1
get tx output hdcp	Get TX output HDCP mode	get tx output hdcp	Follow sink	
get tx usbc5v	Get TX USB-C host input 5V	get tx usbc5v	On	
set tx edid to y	Set TX input EDID to (y=0~18) y=00: Copy EDID from RX HDMI output (default) y=01: 1920x1080p60Hz, Audio 2CH PCM y=02: 1920x1080p60Hz, Audio 5.1CH DTS/DOLBY y=03: 1920x1080p60Hz, Audio 7.1CH DTS/DOLBY/HD y=04: 3840x2160p30Hz 4:4:4, Audio 2CH PCM y=05: 3840x2160p30Hz 4:4:4, Audio 5.1CH DTS/DOLBY y=06: 3840x2160p30Hz 4:4:4, Audio 7.1CH DTS/DOLBY/HD y=07: 3840x2160p60Hz 4:2:0, Audio 2CH PCM y=08: 3840x2160p60Hz 4:2:0, Audio 5.1CH DTS/DOLBY y=09: 3840x2160p60Hz 4:2:0, Audio 7.1CH DTS/DOLBY/HD y=10: 3840x2160p60Hz 4:4:4, Audio 2CH PCM y=11: 3840x2160p60Hz 4:4:4, Audio 5.1CH DTS/DOLBY y=12: 3840x2160p60Hz 4:4:4, Audio 7.1CH DTS/DOLBY/HD y=13: WUXGA 1920x1200p60Hz, Audio 2CH PCM y=14: DVI 1280x1024p60Hz, Audio None y=15: DVI 1920x1080p60Hz, Audio None y=16: DVI 1920x1200p60Hz, Audio None y=17: User Defined 1 y=18: User Defined 2	set tx edid to 0	Set TX input EDID to 00_Copy EDID from RX HDMI output (default)	0

Command	Function	Example	Feedback	Default
get tx edid	Get TX input EDID	get tx edid	TX input EDID to 00_ Copy EDID from RX HDMI output (default)	
get tx edid data	Get TX input EDID data	get tx edid data	TX input EDID <00 FF FF FF....>	
set user edid x <y>	Set user defined EDID (x=0~2) to y x=0: User Defined 1 and User Defined 2 x=1: User Defined 1 x=2: User Defined 2 y=00 FF FF FF (y is 256 bytes EDID data)	set user edid 1 <00 FF FF FF....>	User defined 1 EDID is loaded	
get user edid x	Get user defined EDID (x=0~2) data x=0: User Defined 1 and User Defined 2 x=1: User Defined 1 x=2: User Defined 2	get user edid 1	User defined 1 EDID <00 FF FF FF....>	
set hdbt update	Set SERVICE to HDBT UART for FW update	set hdbt update	HDBT update...	

Note: The feedback of the command of “get status” is as following. (The middle line ends with <LF> <CR> and the last line ends with <CR><LF>.)

```
=====
Status Info USB-C Extender over HDBT
FW V1.00.00
```

```
Input   Cable   HDCP   EDID
USB-C   Connected  HDCP 2.2  00_Copy EDID from RX HDMI output (default)

Output  Cable   Resolution   ColorSpace   ColorDepth   HDCP
HDMI    Connected  3840x2160p60Hz  YUV 4:4:4   8bit         HDCP 2.2
=====
```

7. Application Example

Transmitter

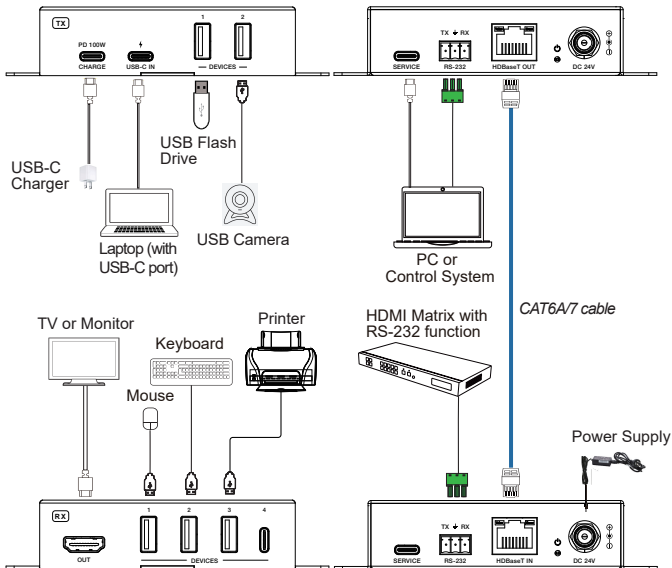

Receiver

HDMI™
HIGH-DEFINITION MULTIMEDIA INTERFACE

The terms HDMI and HDMI High-Definition Multimedia interface, and the HDMI Logo are trademarks or registered trademarks of HDMI Licensing LLC in the United States and other countries.